

5: ;5A

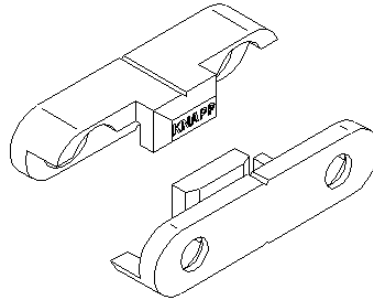

Art.-Nr. K" %'

Deutsch S. 2

English S. %

Français S. &

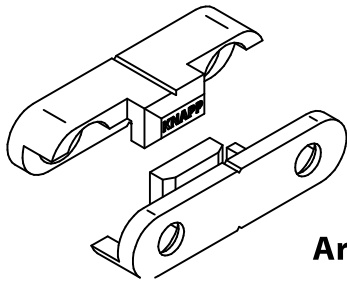

Art.-Nr. K 030

Montageanleitung

Chico

Schiebeverbinder

Ohne Anschlag

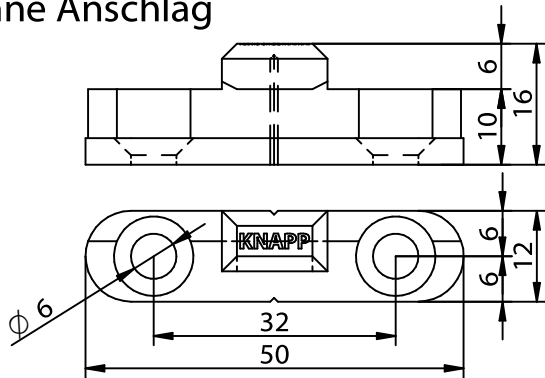

Mit Anschlag

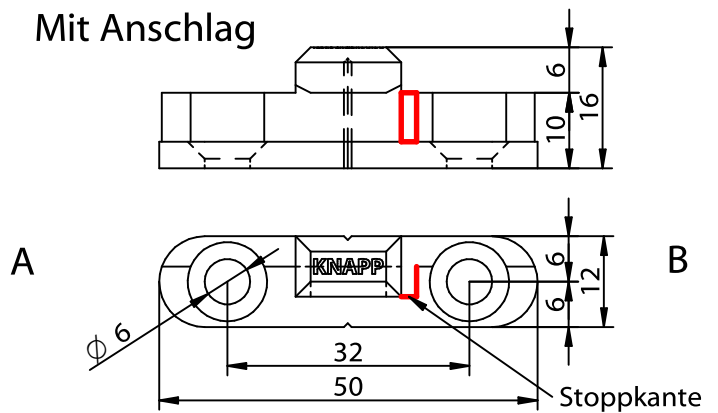

1. Beide Teile ausfräsen

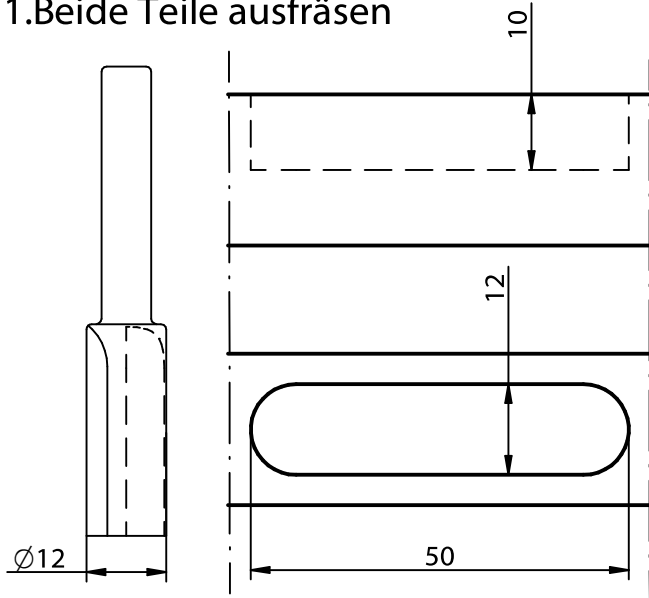

2. Einsetzen und in beide Teile mit je 2 Stück SK $\varnothing 4,5$ mm verschrauben oder 2 Stück EURO-Schraube $\varnothing 6,30$ mm verschrauben

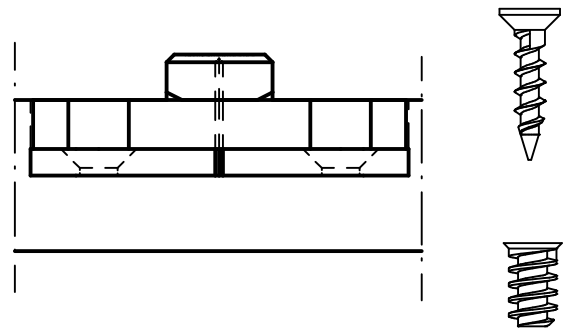

3. Zusammenstecken

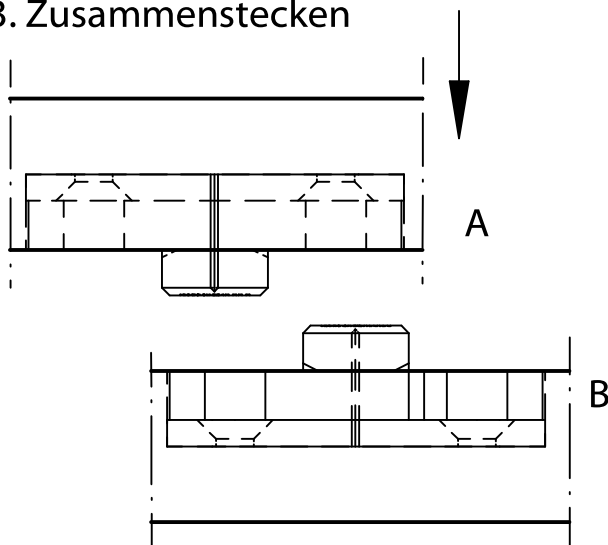

4. Einschieben

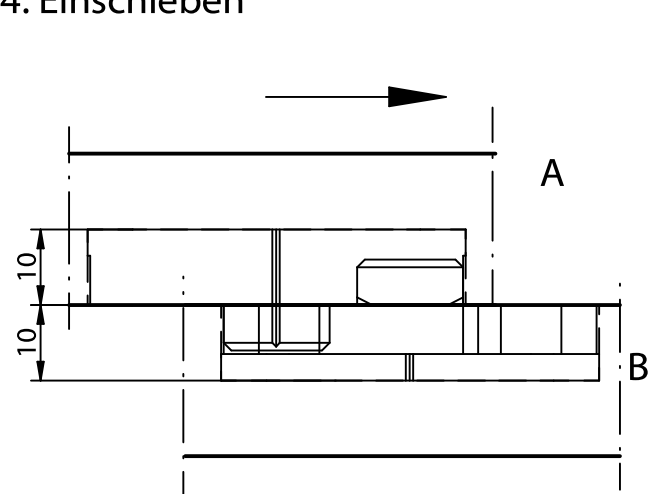

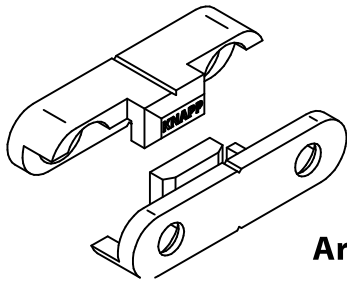

Art.-No. K 030

Construction Manual

Chico

Slide connectors

Without stop

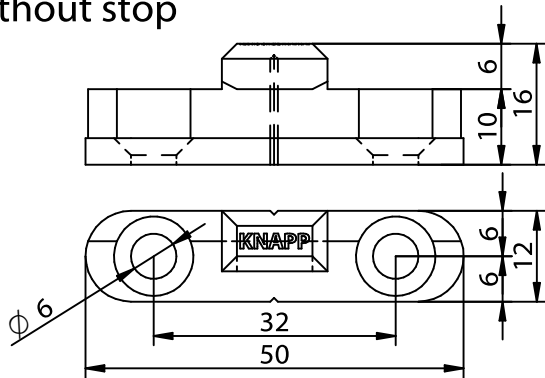

With stop

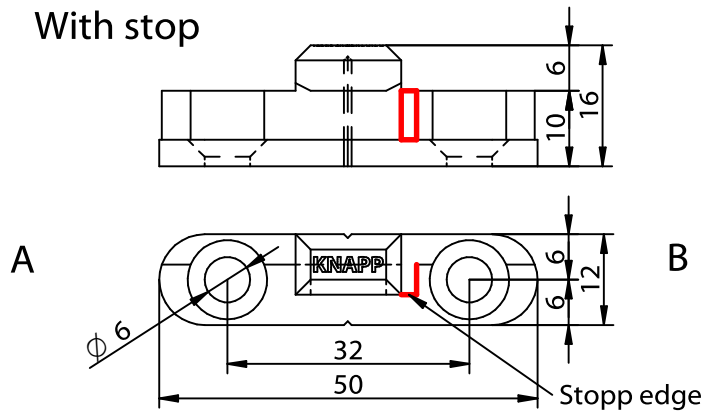

1. Both parts milling

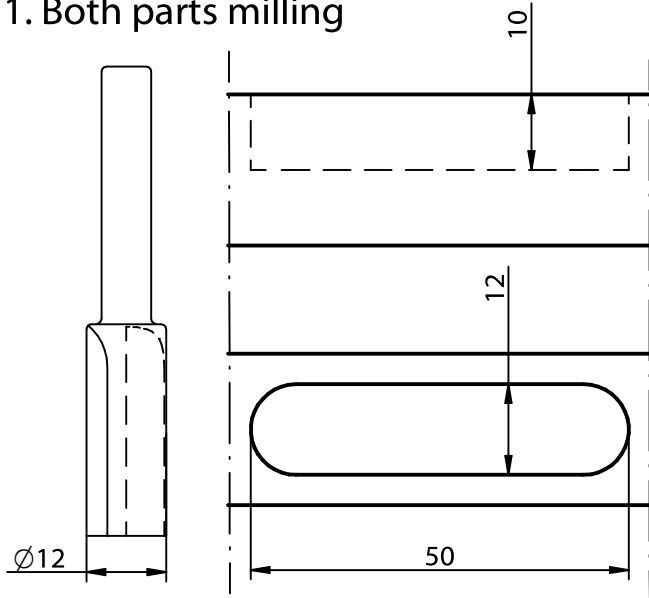

2. Insert and screw into both parts with either 2 SK \varnothing 4.5 mm screws or 2 EURO screws \varnothing 6.30 mm

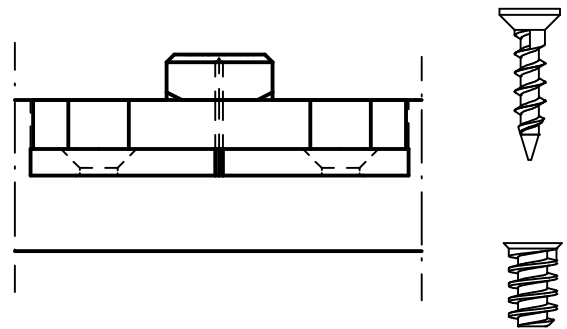

3. Insertion

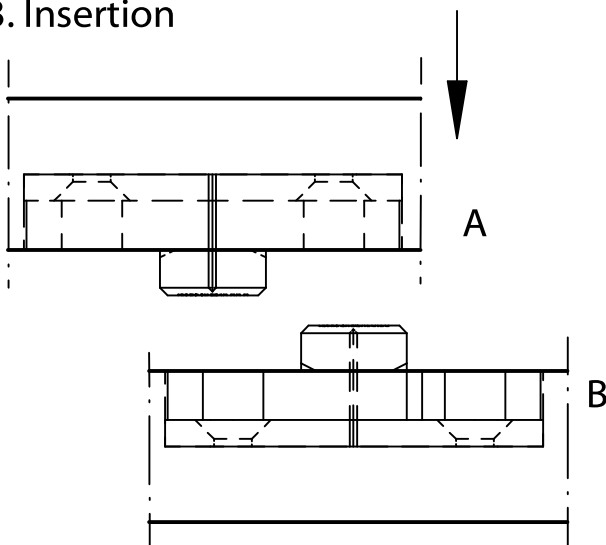

4. Assemble

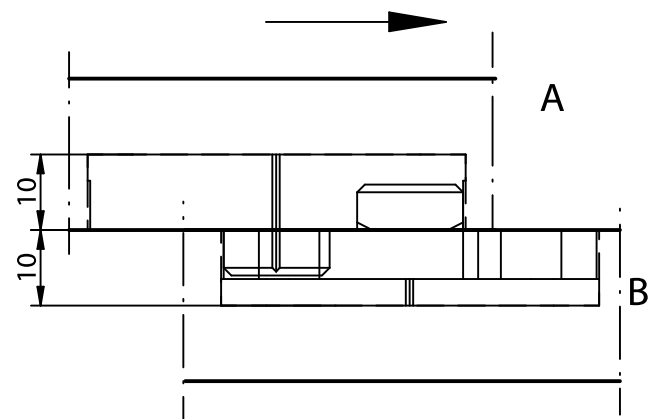

This drawing is the exclusive property of Knapp GmbH.

22.04.2024

© Knapp GmbH. All measures in mm - Errors excepted. VERSION 01

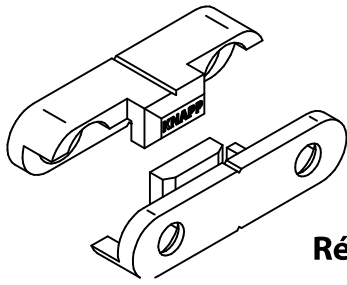

Réf. K 030

Notice de montage

Chico

Assembleur à coulisser

Sans butée

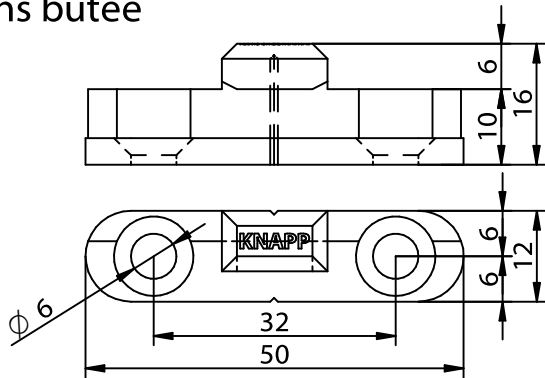

Avec butée

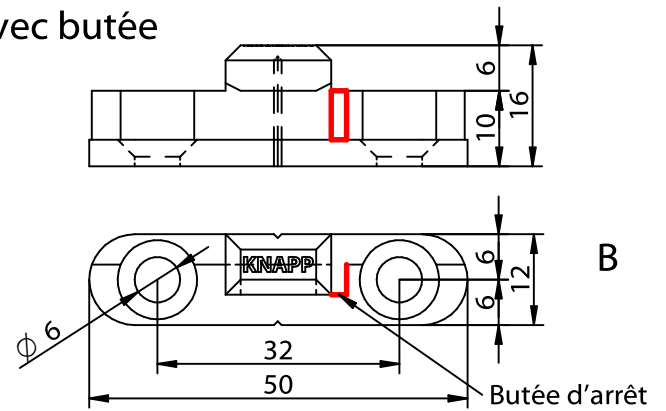

1. Réaliser l'usinage d'encastrement

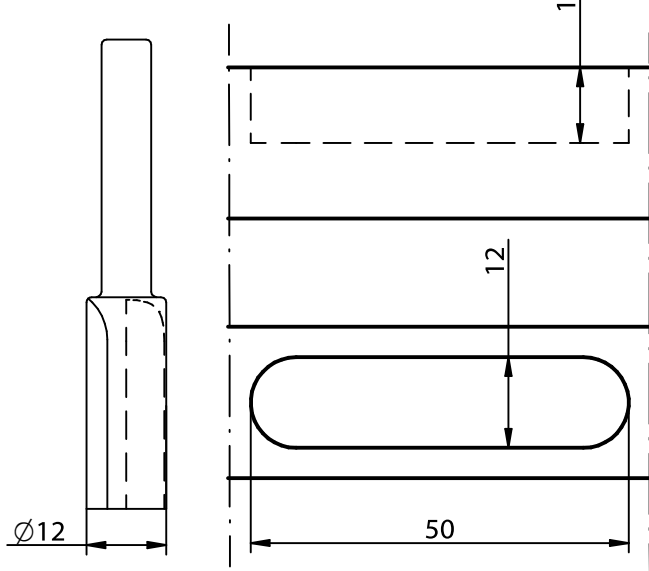

2. Mettre en place et visser les pièces avec
2 vis TF \varnothing 4,5 mm ou
2 vis Euro \varnothing 6,30 mm

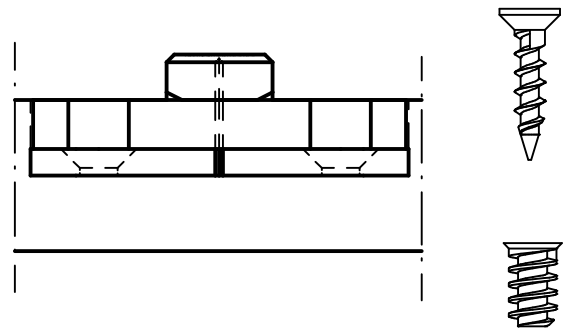

3. Emboîter

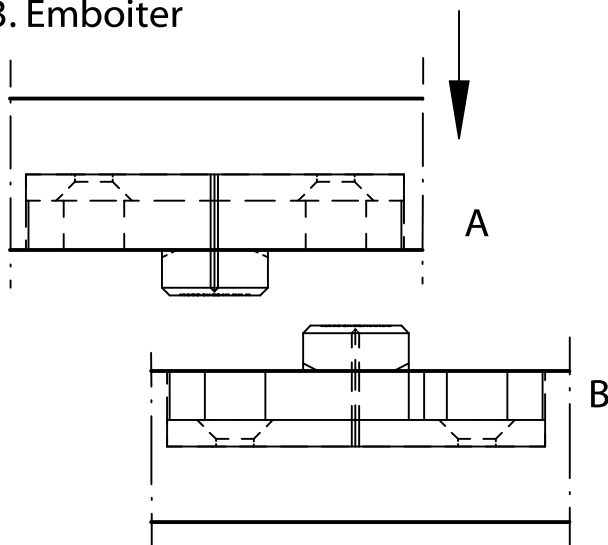

4. Coulisser

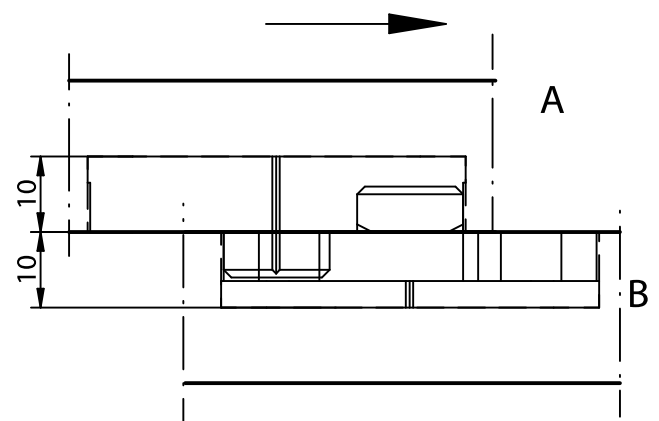

KNAPP®
connectors.com

Knapp GmbH | Wassergasse 31 | A-3324 Euratsfeld | Tel.: +43 (0)7474 / 799 10 | Fax: +43 (0)7474 / 799 10 99

Knapp GmbH | Vertrieb Deutschland | Föhrenweg 1 | D-85591 Vaterstetten | Tel.: +49 (0)8106 / 99 55 99 0 | Fax: +49 (0)8106 / 99 55 99 20 | E-Mail: info@knapp-verbinder.com

Knapp GmbH | Distribution France et pays francophones | 20 Rue des Fleurs | F - 67880 Innenheim | Tel.: +33 (0)3 88 48 17 87 |

E-Mail : france@knapp-connectors.com