

Art.-Nr.

Deutsch S.2
Englisch S.6
Français S.10

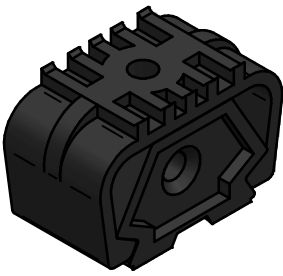

Montageanleitung

DEKCLICK® MINI

Art.- Nr. K013, K014

aus hochfestem elastischen Kunststoff

Klemmverbinder

DEKCLICK® MINI - Block
Art.- Nr. K013

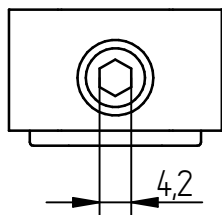
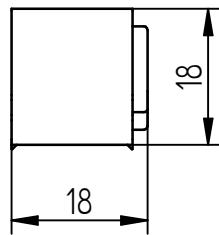
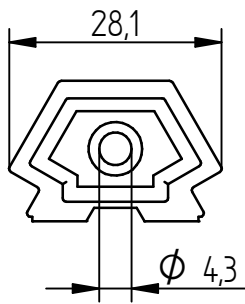

DEKCLICK® MINI - Klammer
Art.- Nr. K014

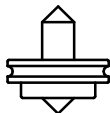
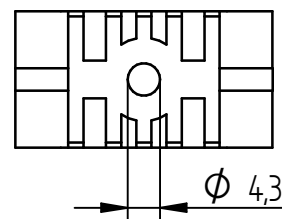
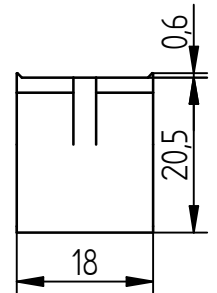
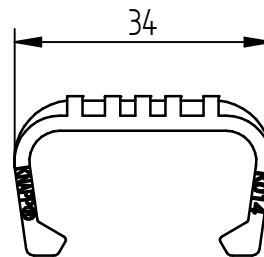

Körner Dekclick Mini
Art.- Nr. K015



PH- Schraube 4,5x30mm
Art.- Nr.Z785



SK- Schraube 4,5x35 mm A2
Art.- Nr.Z409

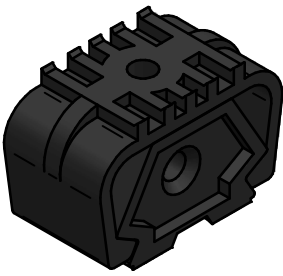

Verarbeitung mit Block, Klammer

1. Markieren Sie die Positionen mit dem Körner auf den Teilen A und B.

Block anschrauben

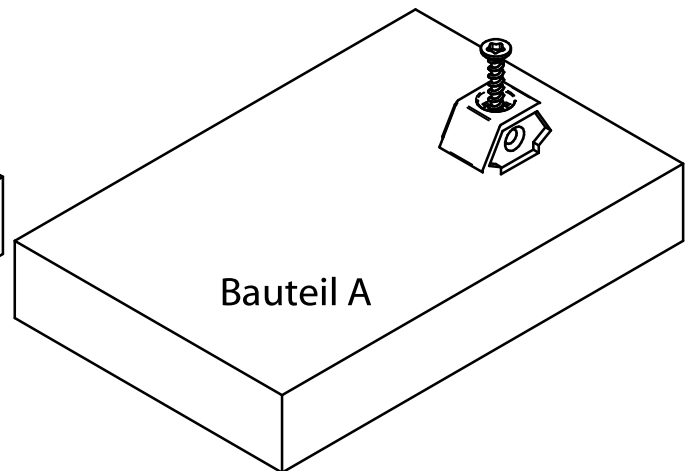
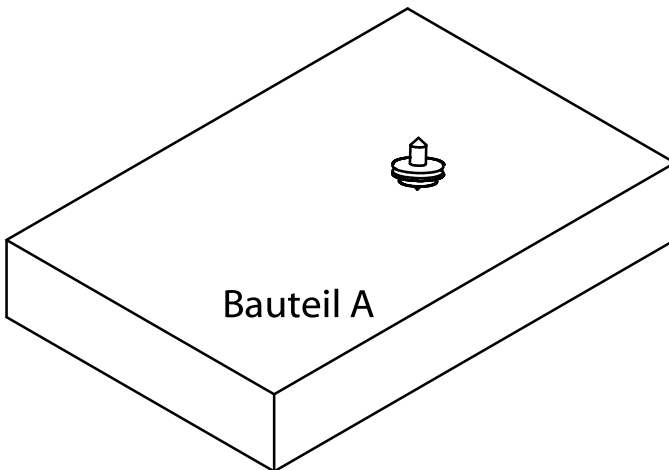

2. Klammer positionieren und verschrauben.

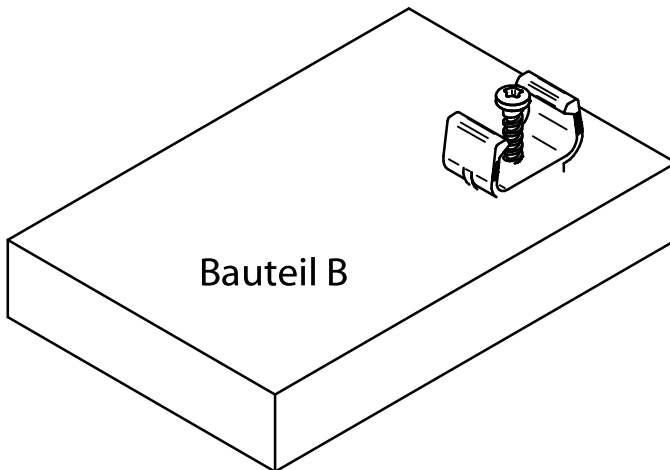

3. Bauteile A/ B zusammenklipsen.

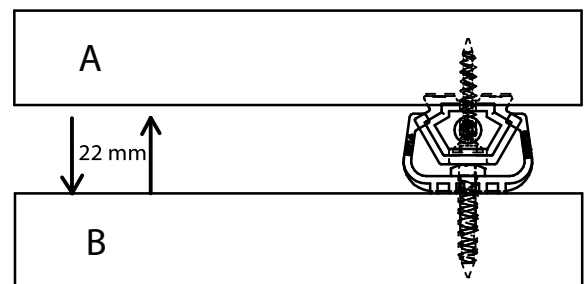
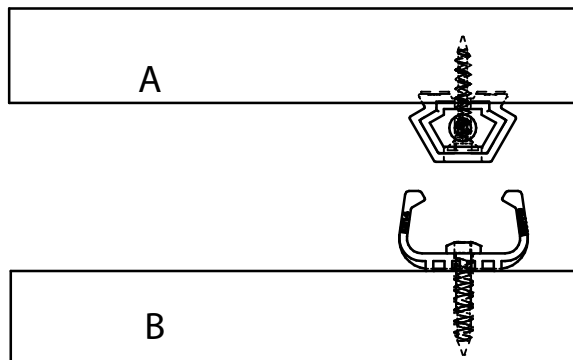

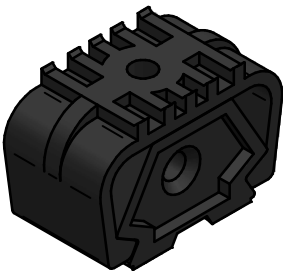

Verarbeitung mit Klammer

1. Klammer positionieren und verschrauben.

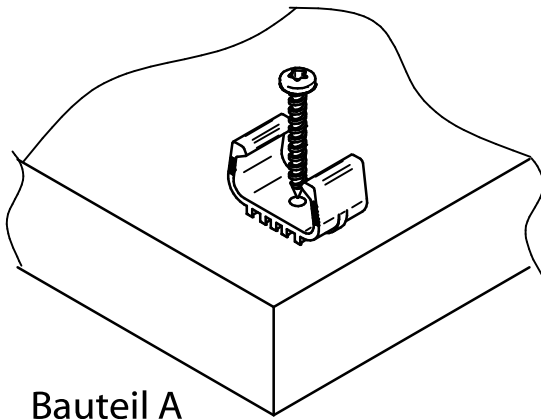

Bauteil A

2. Blockleiste Ausführung

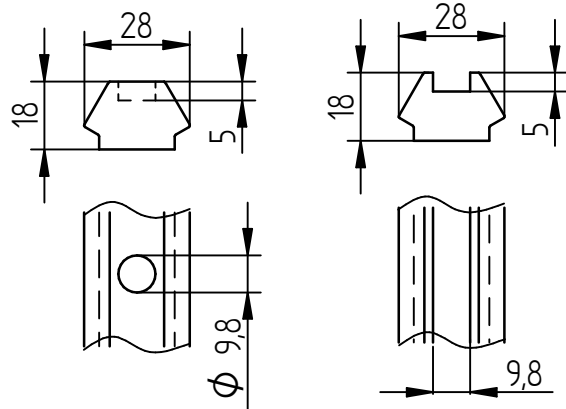

Bauteil B
mit Bohrung zentriert

Bauteil B
mit Nut flexibel

3. Blockleiste auf Grund montieren

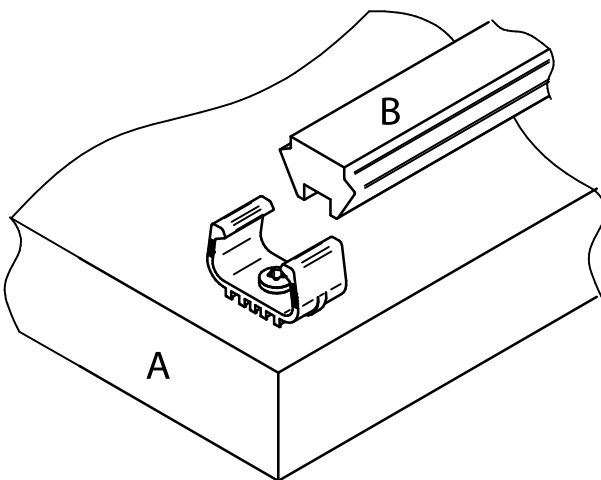

A

B

4. Bauteil A auf B klipsen

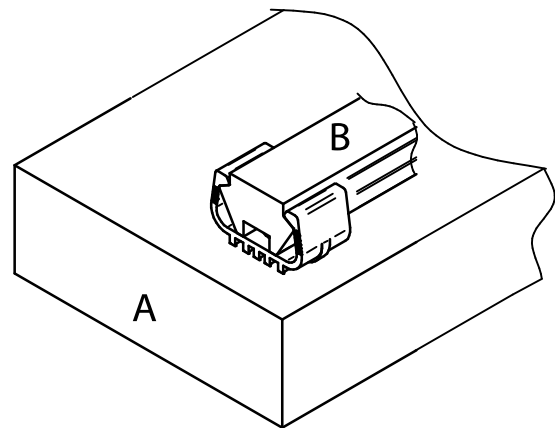

A

B

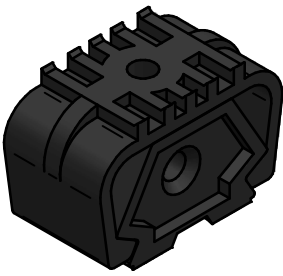

Stumpfe Winkel Verbindung

1. Block positionieren und verschrauben.

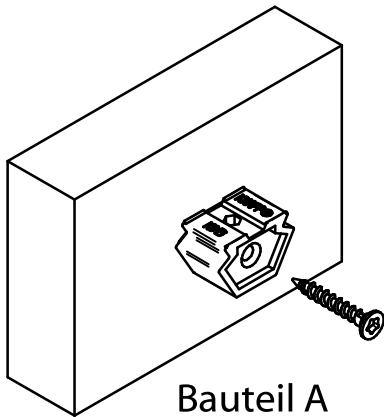

Bauteil A

2. Klammer positionieren und verschrauben.

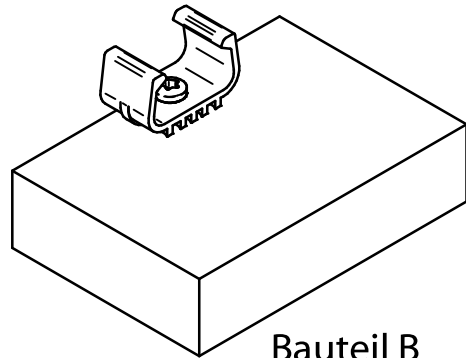

Bauteil B

3. DEKLICK MINI zusammenklipsen.

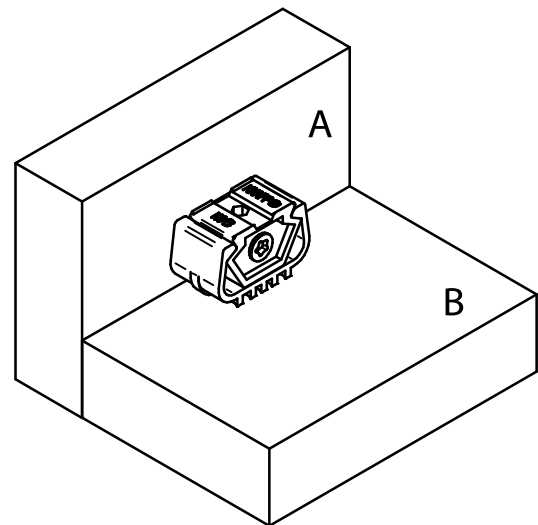
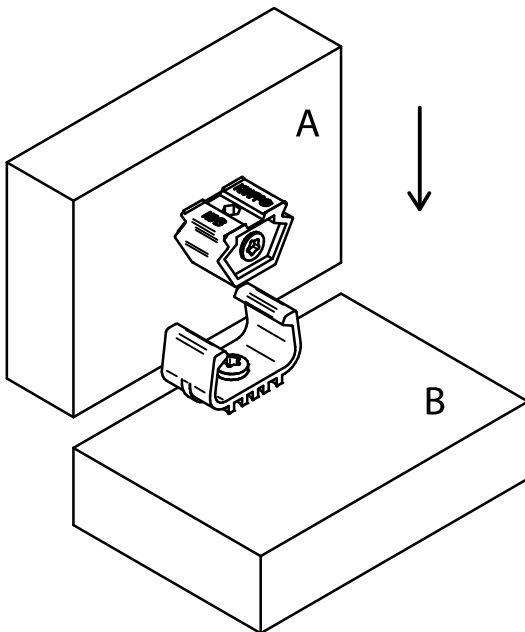

Verbindungsmöglichkeiten

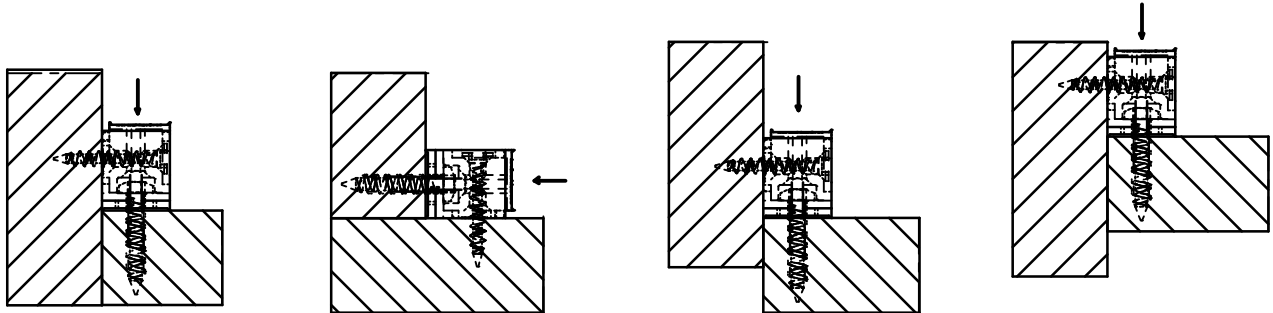

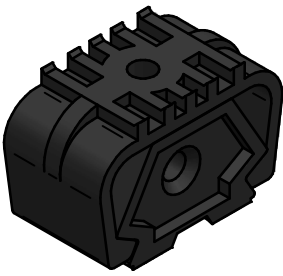

Assembly Instructions

DEKLICK® MINI

Art.- No. K013, K014

Heavy-duty, flexible plastic ,Clamp connector

DEKLICK® MINI - Block
Art.- No. K013

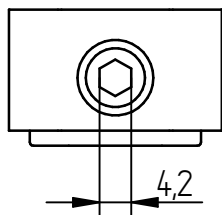
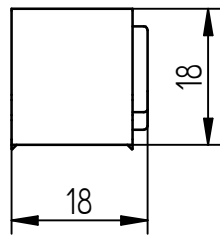
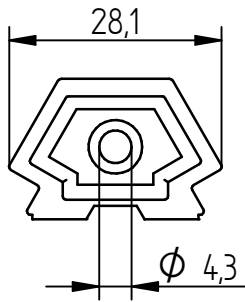

DEKLICK® MINI - clamp
Art.- No. K014

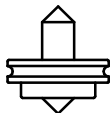
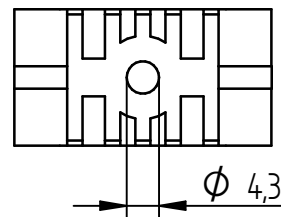
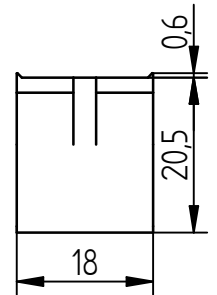
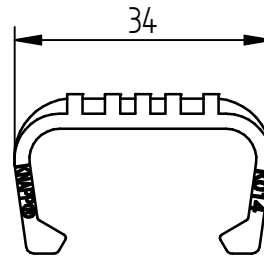

Center punch Deklick Mini
Art.- No. K015

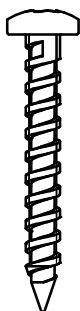

PH- screw 4,5x30 mm
Art.- No.Z785



CS- screw 4,5x35 mm A2
Art.- No.Z409

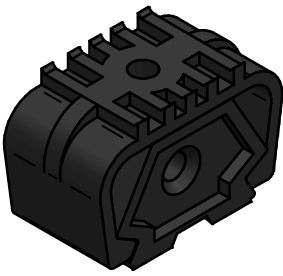

Assembly Instructions

DEKCLICK® MINI

Art.- No. K013, K014

Clamp connector

Assembly with block and screw clamp

1. Mark positions using the center punch on parts A and B.

Screw the block in place

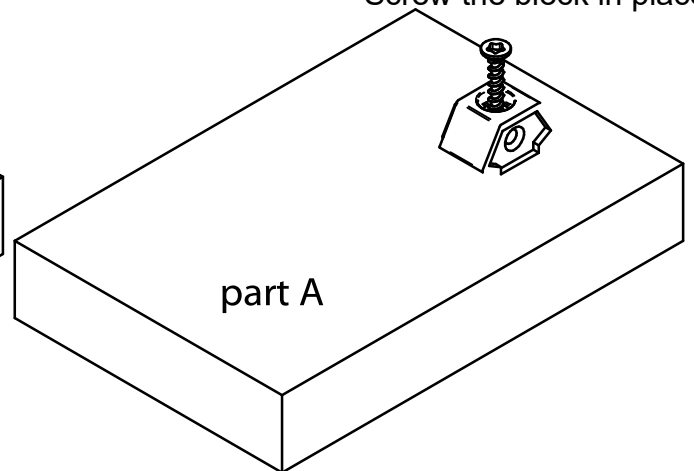
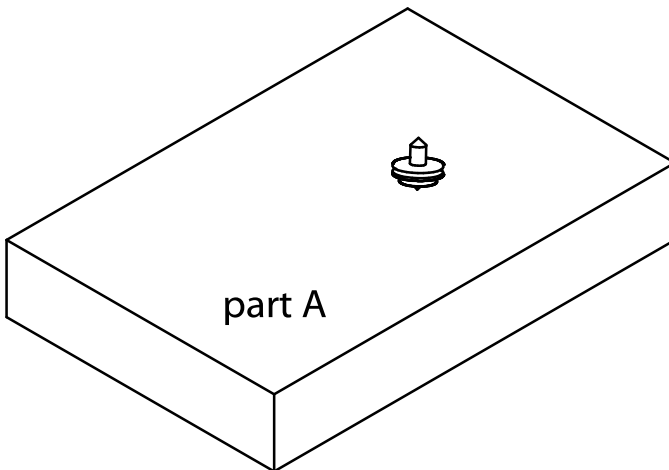

2. Position the clamp and screw in place.

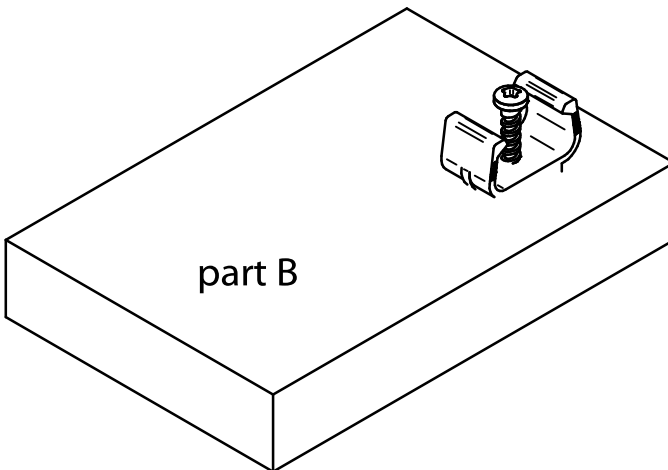

3. Clip part A/ B together.

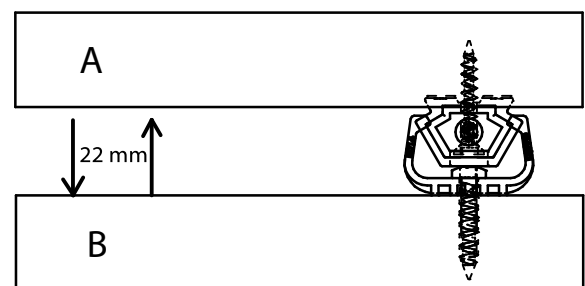
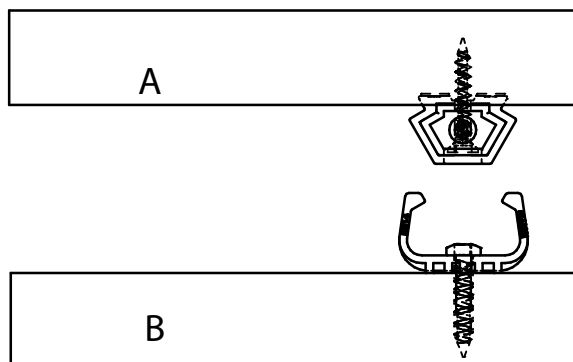

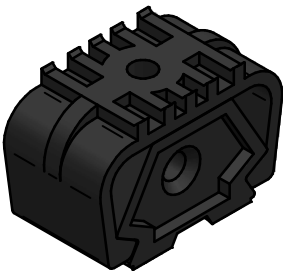

Assembly Instructions

DEKCLICK® MINI

Art.- No. K013, K014

Clamp connector

Processing with clamp

1. Position the clamp and screw it in place.

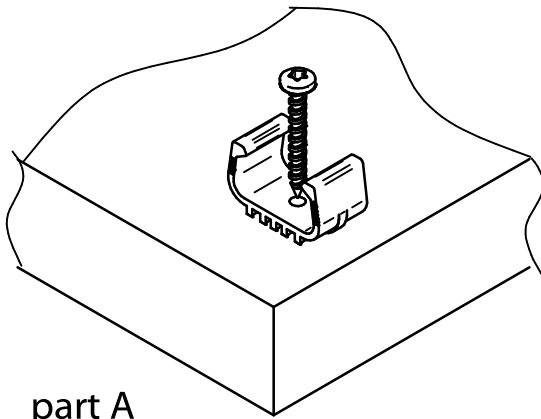

2. Block rail version

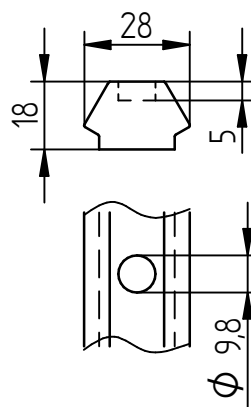

part B
centered with hole

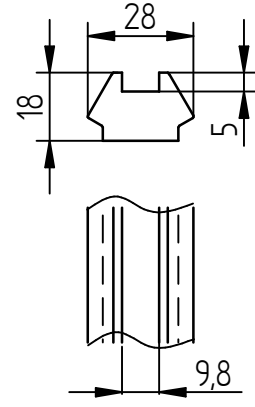

part B
with flexible groove

3. Mount the block rail on the base

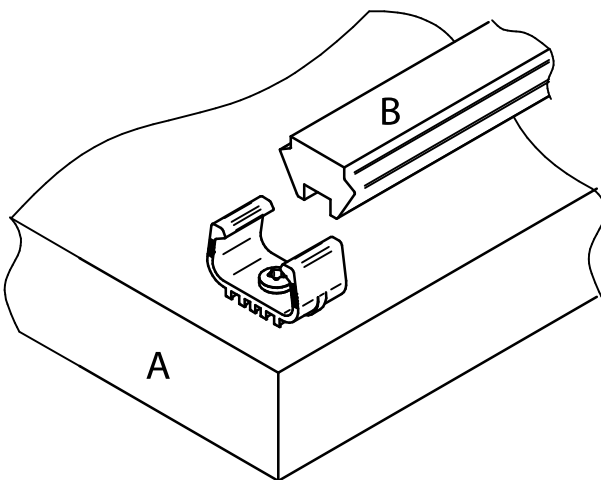

4. Clip part A to B

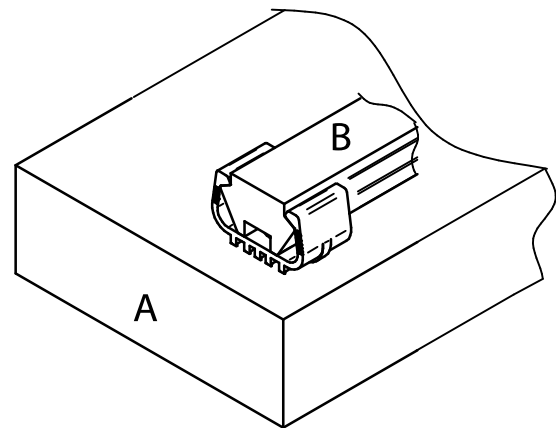

This drawing is the exclusive property of Knapp GmbH.

© Knapp GmbH. All measures in mm - Errors excepted. VERSION 01 07.01.2025

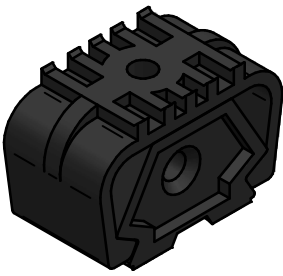

Assembly Instructions

DEKCLICK® MINI

Art.- No. K013, K014

Clamp connector

90° angle connection

1. Position the block and screw in place.

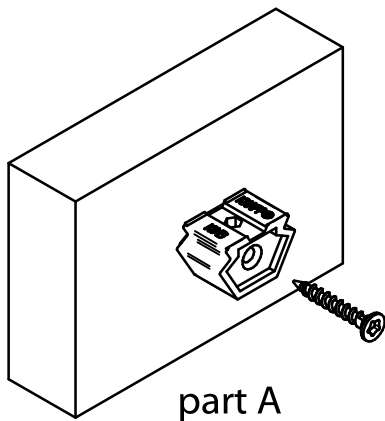

2. Position the clamp and screw in place.

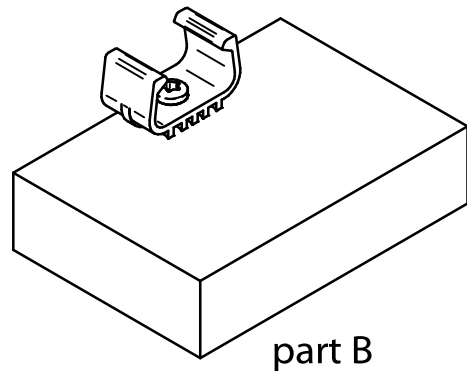

3. Clip together DEKCLICK MINI

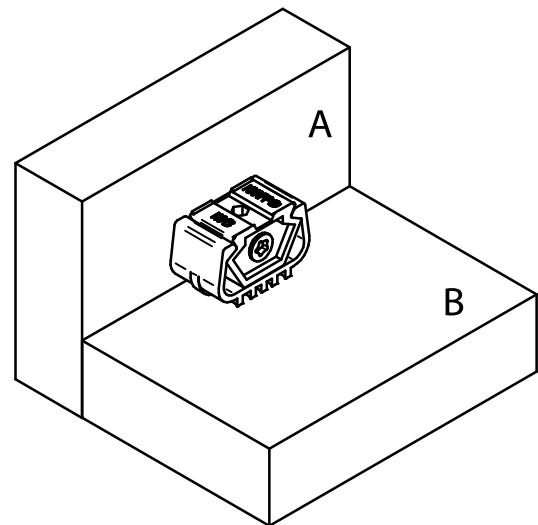
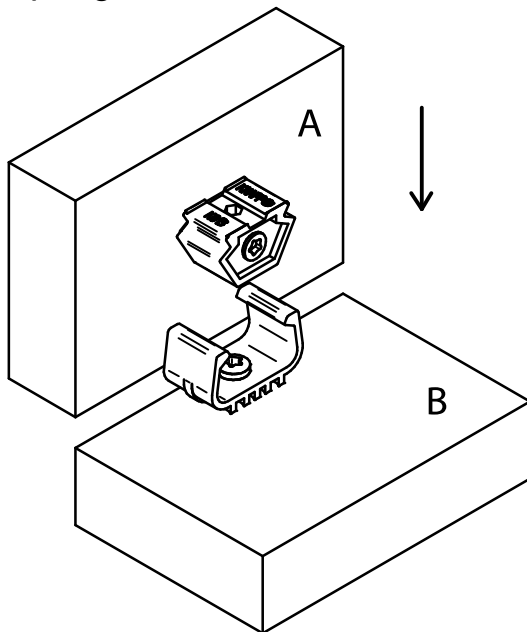

Connection examples

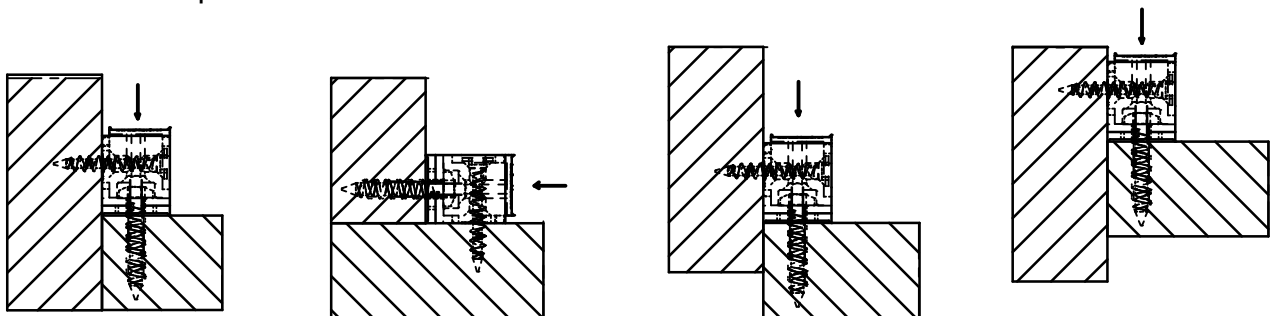

This drawing is the exclusive property of Knapp GmbH.

© Knapp GmbH. All measures in mm - Errors excepted. VERSION 01 07.01.2025

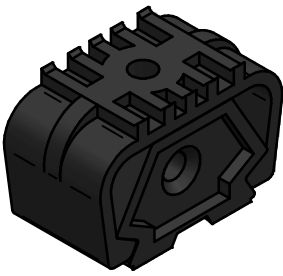

DEKLICK® MINI

Réf. K013, K014

Clip de fixation en plastique souple très résistant

Bloc DEKLICK® MINI
Réf. K013

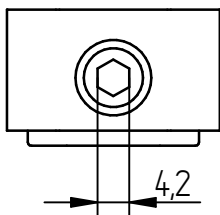
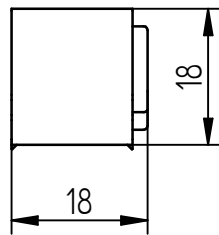
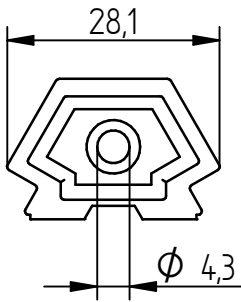

Clip DEKLICK® MINI
Réf. K014

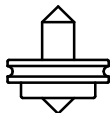
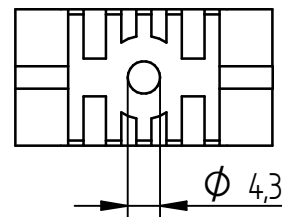
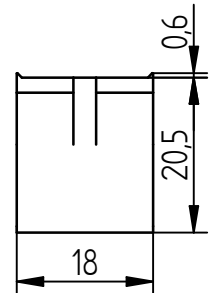
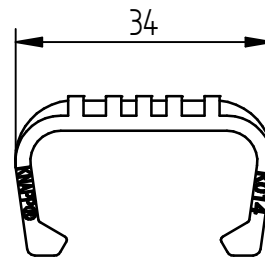

Pointeur Deklick Mini
Réf. K015

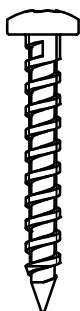

Vis TR 4,5x30 mm
Réf. Z785



Vis TF 4,5x35 mm A2
Réf. Z409

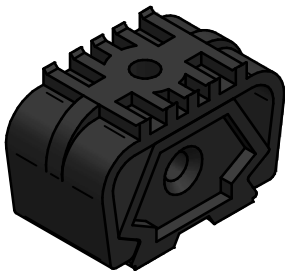

Réf. K013, K014

Clip de fixation

Mise en œuvre avec bloc et clip

1. Marquer les positionnements à l'aide du ou des pointeurs sur les pièces A et B.

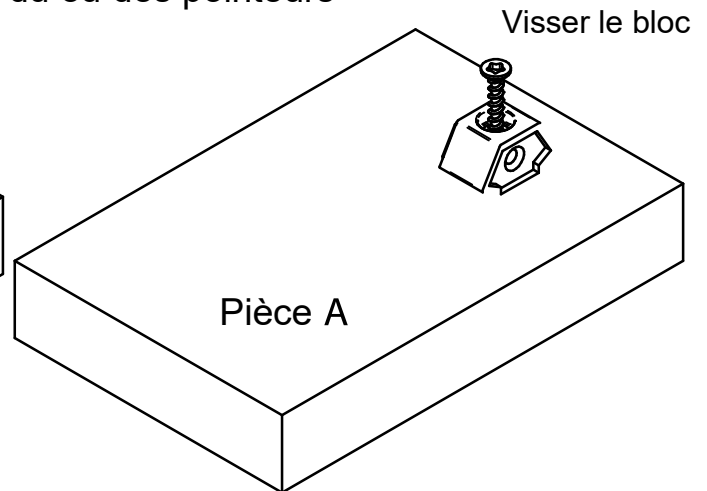
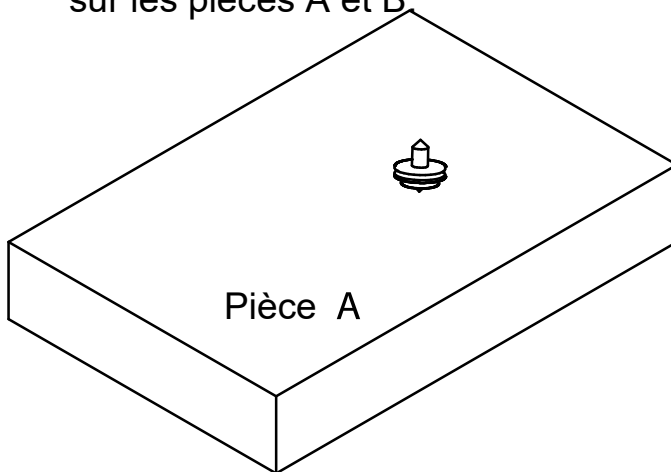

2. Positionner le clip et visser.

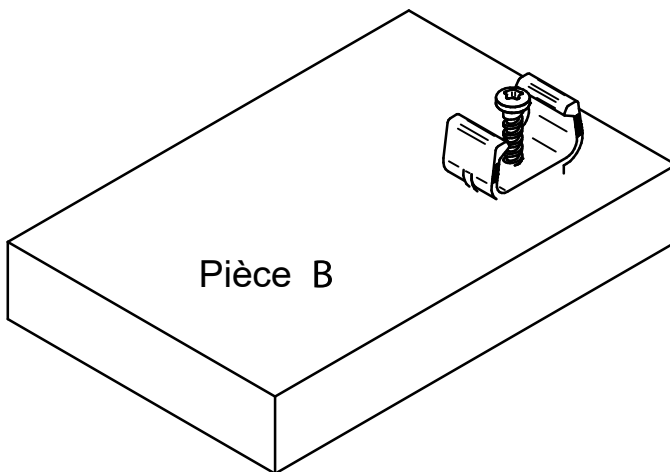

3. Clipser les pièces A/ B ensemble.

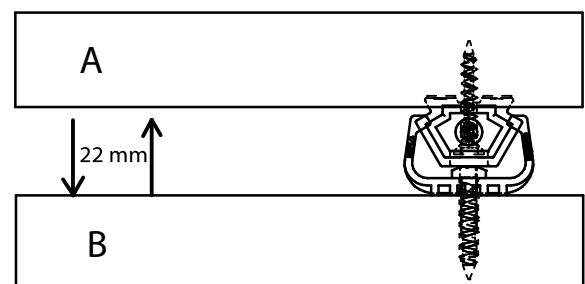
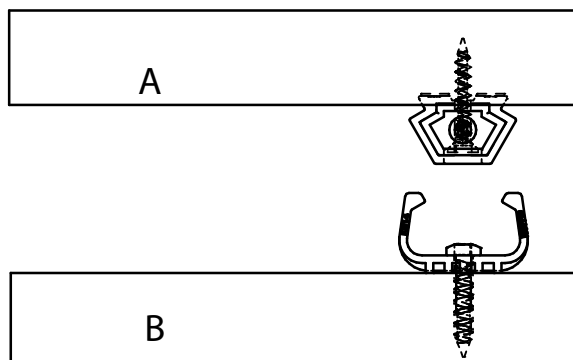

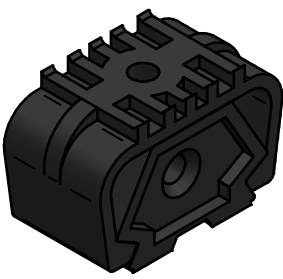

Réf. K013, K014

Clip de fixation

Mise en œuvre avec clip et profil bois

1. Positionner le clip et visser

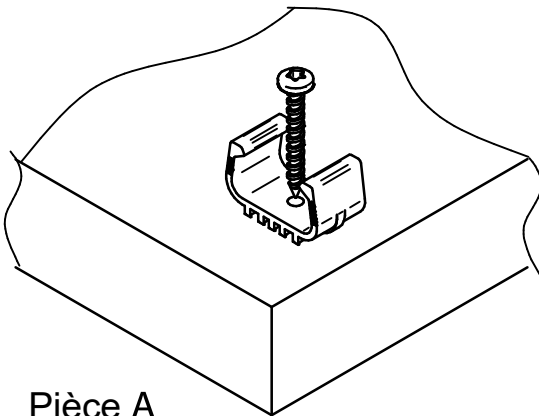

2. Profils d'accroche bois

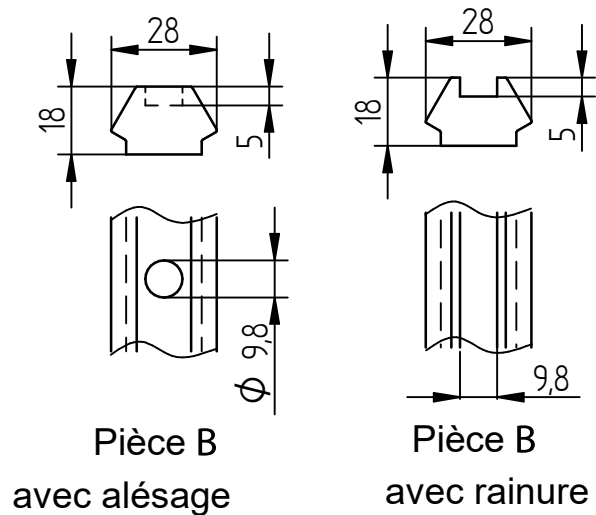

3. Suivant la configuration, fixer la pièce A ou la pièce B sur le support

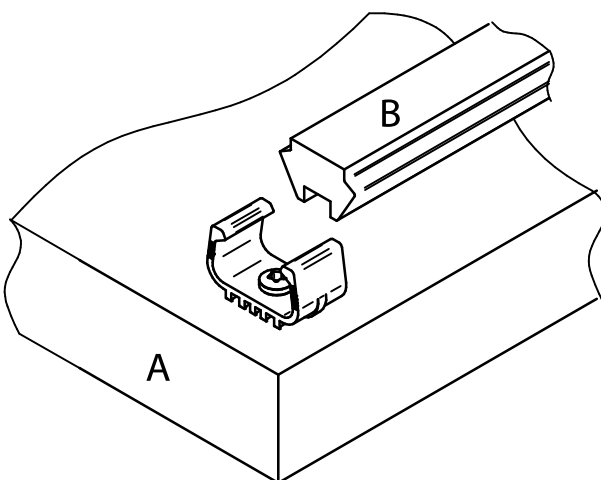

4. Suivant la configuration, monter la pièce A sur B ou la pièce B sur A

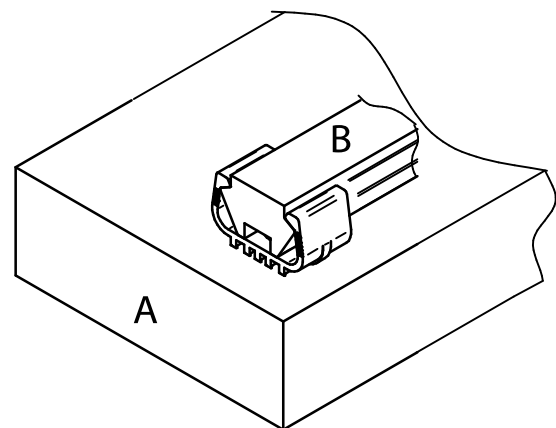

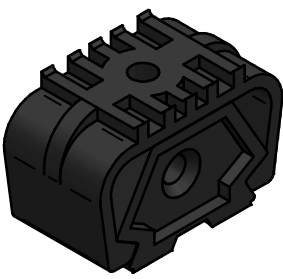

DEKCLICK® MINI

Réf. K013, K014

Clip de fixation

Assemblage à angle droit

1. Positionner et fixer le bloc.

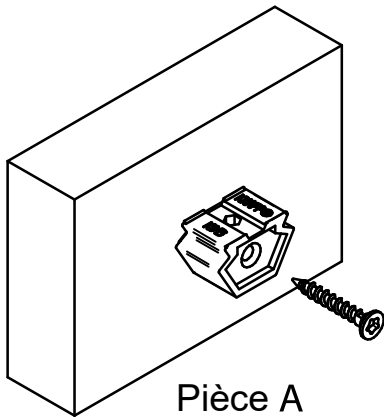

2. Positionner le clip et visser.

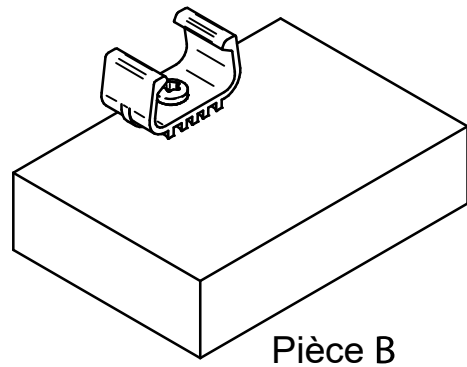

3. Clipser les pièces A et B ensemble

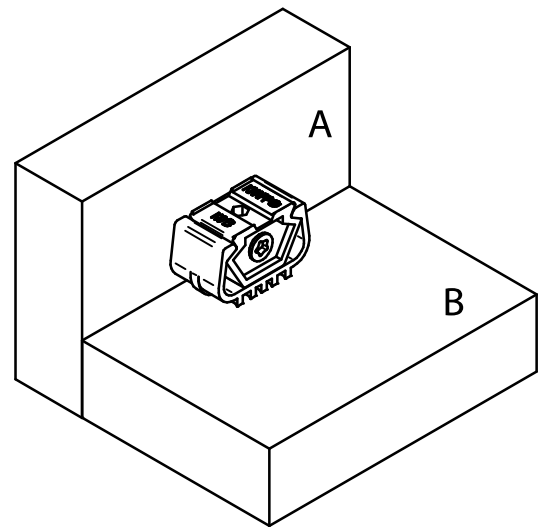
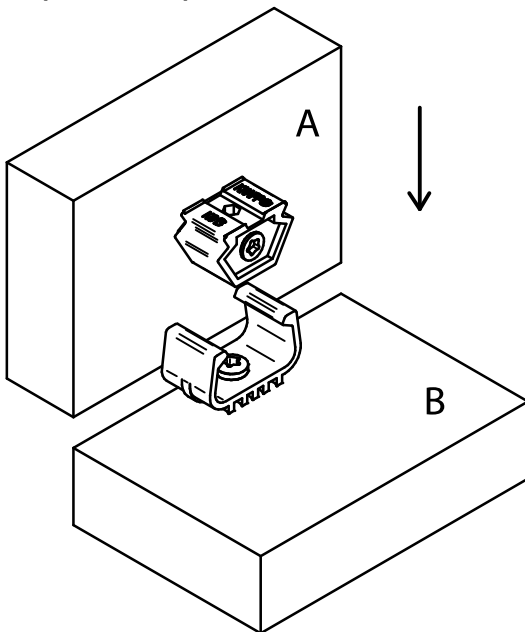

Exemples de possibilités de mise en œuvre

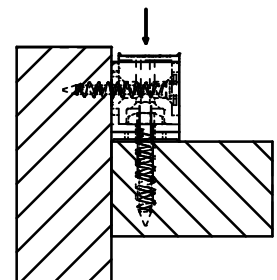
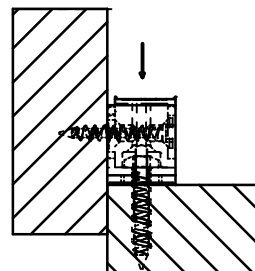
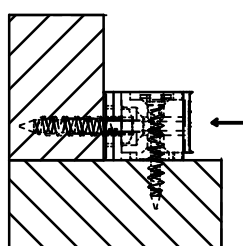
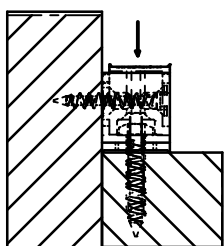

KNAPP®
connectors.com

Knapp GmbH ■ Wassergasse 31 ■ A-3324 Euratsfeld ■ Tel.: +43 (0)7474 / 799 10 ■ Fax: +43 (0)7474 / 799 10 99
Knapp GmbH ■ Vertrieb Deutschland ■ Föhrenweg 1 ■ D-85591 Vaterstetten ■ Tel.: +49 (0)8106 / 99 55 99 0 ■ Fax: +49 (0)8106 / 99 55 99 20 ■ E-Mail: info@knapp-verbinder.com
Knapp GmbH Sàrl ■ Filiale France ■ 1A Rue du Stade ■ F - 67880 Innenheim Tel. : +33 (0)3 88 48 17 87 ■ Fax: +33 (0)9 70 62 81 87 ■ E-Mail : france@knapp-connectors.com